



Innovative and Powerful Features!

- ◆ For global use with single- and two phase wide-range input 100/230–500 VAC
- ◆ Rugged metal case for harsh industrial environments
- ◆ Industrial operating temperature range: –25°C to +70°C
- ◆ Power OK signal
- ◆ Remote On/Off
- ◆ Shock and vibration-proof
- ◆ Indefinite short circuit, overvoltage and overtemperature protection
- ◆ Redundancy module
- ◆ Buffer module for power backup
- ◆ Battery controller module
- ◆ 3-year product warranty



The successful TSP series of high performance DIN-rail mount power supplies has been expanded with 3 additional models which features an ultrawide input range of 85-132/187-550VAC. With these input voltages the power supplies can be used in almost all single- and multi phase power networks worldwide.

A high, continuously available power reserve guarantees reliable start-up of loads with high inrush currents. Excellent electrical specifications and high immunity against electrical disturbances make these compact power supplies the best choice to power sensitive loads in industrial process control systems, machine tools or any other demanding industrial application. The power supplies comply also with IEC/EN 61204-3, the EMC standard for Industrial environment.

3 add-on modules for extra functions offer a great flexibility in system applications. A module for redundant operation with true power sharing is available. With the battery controller module the power supplies can be extended to a perfect DC-UPS system. The buffer module provides power back-up for up to 4 seconds without the need of any batteries. Easy and vibration proof installation with pluggable screw terminal block and snap-on mounting on DIN-rails.

Models

Order Code	Output Voltage (Vnom)	*Output Current (Imax)	Output Power (Pmax)
TSP 180–124WR	24 VDC (adjustable 24 - 28 VDC)	7.5 A	180 W
TSP 360–124WR		15.0 A	360 W
TSP 600–124WR		25.0 A	600 W

* Max. current at nominal output voltage and operating temperature up to 40°C max.

Input Specifications

Applicable 3-phase networks	– TN, TT Systems: 500 VAC Star configuration (EN60950, UL508) 500 VAC Delta (UL508 only) – IT Systems: 400 VAC Delta (IEC-62103) 230 VAC Delta (IEC-60950) 500 VAC (UL508)
Input voltage ranges	85–132 VAC/187–550 VAC 50/60 Hz range selectable by selector switch 187–264 VAC/323–550 VAC autoranges
Harmonic limits	EN 61000-3-2, Class A (for limited output power)
Holdup time	20 ms min. (full load 230 – 500 VAC)
Inrush current	115 VAC 230 VAC TSP 180-124VWR t.b.a < 23 A TSP 360-124VWR t.b.a < 46 A TSP 600-124VWR t.b.a < 50 A
Efficiency	88 % typ.

Output Specifications

Output voltage adjustable range	24–28 VDC
Regulation	– Input variation 0.5 % max. – Load variation (10–100 %) 0.5 % max. – Load variation (10–100 %) parallel mode 2.0%
Ripple and noise (20MHz bandwidth)	100 mV pk-pk typ. (150 mV pk-pk max. at I _{max})
Electronic short circuit protection	current limitation at 125 % of I _{max} . constant current, automatic recovery
Output overvoltage protection	34 V
Overload protection	electronic overload protection
Overtemperature protection	switch off at overtemperature, automatic restart
Status indicator	dual colour LED (green: DC OK, red: DC off)
Power OK signal	– trigger threshold: 18 – 22 V – relay output DC OK = contact closed (rated: 30 VDC/1.0 A)
Max. capacitive load	unlimited

General Specifications

Operating temperature range	–25°C to +70°C max. (for derating see graph A on page 3)
Cooling	convection cooling, no internal fan
Storage temperature	–25°C to +85°C
Humidity (non condensing)	95 % rel. H max.
Pollution degree	2
Temperature coefficient	0.02 %/K
Reliability, calculated MTBF	>350'000 heures in accordance to IEC 61709
Remote On/Off	by ext. contact. DC on: -S contact open DC off: -S connected via 1 Kohm to -Vout
Isolation	according to IEC/EN 60950-1, UL 60950-1, UL 508
Safety standards	– Information technology equipment IEC/EN 60950-1, UL 60950-1, CSA-C22.2 No. 60950-1-03 – Industrial control equipment UL 508C, CSA-C22.2 No. 107 – Electrical equipment of machines EN 60204 – Electronic equipment for power installation EN 50178 – Safety transformers for SMPS EN 61558-2-4

All specifications valid at nominal input voltage, full load and +25°C after warm-up time unless otherwise stated.

General Specifications

Safety approvals and certifications	– CB scheme (for IEC 60950-1)	www.tracopower.com/products/tsp-wr-cb.pdf UL 60950-1 rec. File: e181381, UL 508C listed File: pending www.ul.com -> certifications (file no. 219759) for UL 60950-1 CSA-22.2 No. 60950-1-03, CSA C22.2 No. 1071-01 www.tracopower.com/products/tsp-wr-csa.pdf for IEC/EN 60950-1, EN 60204, EN 61558-2-4 www.tracopower.com/products/tsp-wr-gs.pdf www.tracopower.com/products/tsp-wr-siq.pdf
	– UL approvals	
	– CSA certificate	
	– GS certificate	
	– SIQ certificate (IEC/EN 60950-1)	
Safety class	Degree of electrical protection I (IEC 536)	
Case protection	IP 20 (IEC 529)	
Electromagnetic compatibility (EMC), Emissions	IEC/EN 61000-6-3, IEC/EN 61204-3 – Conducted RI suppression on input – Radiated RI suppression	
Electromagnetic compatibility (EMC), Immunity	IEC/EN 61000-6-2, IEC/EN 61204-3 – Electrostatic discharge (ESD) IEC/EN 61000-4-2 4 kV / 8 kV – Radiated RF field immunity IEC/EN 61000-4-3 10 V / m – Electrical fast transient / burst immunity IEC/EN 61000-4-4 2 kV – Surge immunity IEC/EN 61000-4-5 1 kV / 2 kV – Immunity to conducted RF disturbances IEC/EN 61000-4-6 10 V – Power frequency field immunity IEC/EN 61000-4-8 30 A / m – Voltage dips IEC/EN 61000-4-11	
Environment	– Vibration acc. IEC 60068-2-6; – Shock acc. IEC 60068-2-27 3 axis, sine sweep, 10-55 Hz, 1g, 1oct/min 3 axis, 15 g half sine, 11 ms	
Enclosure material	aluminium (chassis) / zinc plated steel (cover)	
Mounting	– DIN-rail mounting for DIN-rails as per EN 50022-35x15/7.5 (snap-on with self-locking spring) with wall mounting bracket - see page 10 – Wall mounting (option)	
Connection	detachable screw terminals (plugs included) 2 terminals per output	

Output Power Derating

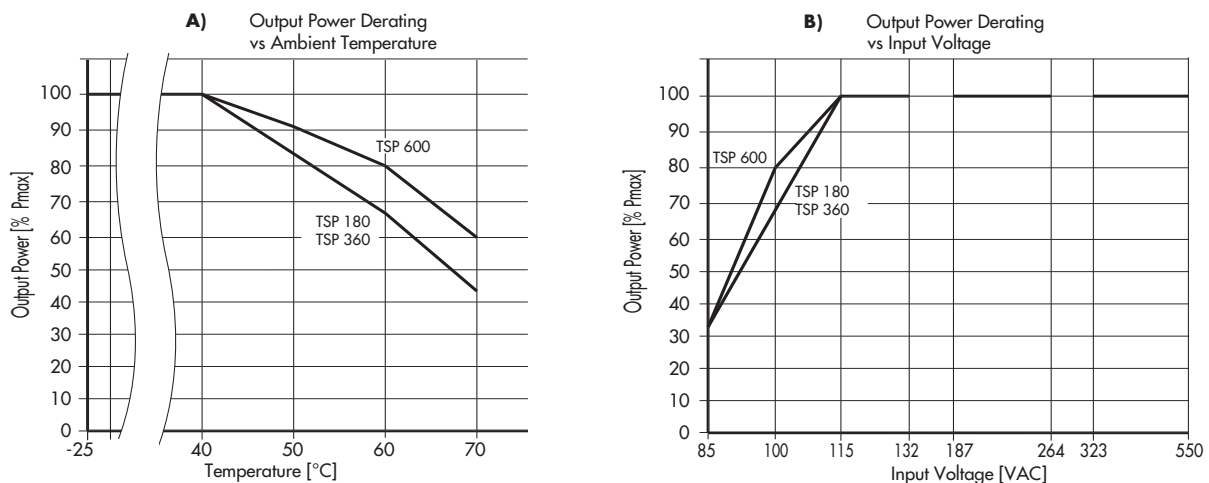

All specifications valid at nominal input voltage, full load and +25°C after warm-up time unless otherwise stated.

TSP-REM360 Redundancy Module

With this module and two power supplies of the TSP-WR series (of same type) a highly reliable, true redundant power system can be configured without any additional components. This module enforces equivalent sharing of the output current by each power supply. The system is fully redundant and provides output power even if one power supply has completely failed e.g. by short circuit on the output. In the event of either power supply failing or being disconnected, the second unit will automatically supply the full current to the load. The redundancy of the system is monitored and if lost, indicated by an alarm output. The inputs are hot swappable and can be loaded up to 15A each.



Models

Order Code (includes terminal plugs)	Input	Max Power per Input	Output Voltage adjust.	Output Power max.
TSP-REM360	2 x 24 VDC	2 x 360 W	24 VDC (24 - 27 VDC)	360 W
TSP-REM600	2 x Control input	2 x 600 W		600 W

Function Diagram

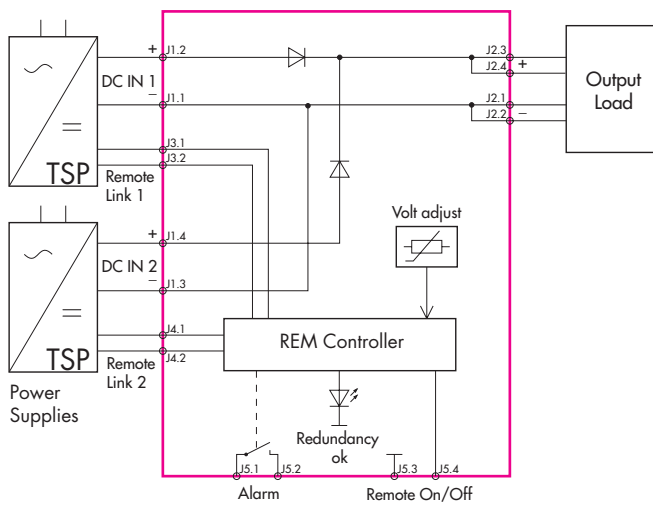

Connector Positions

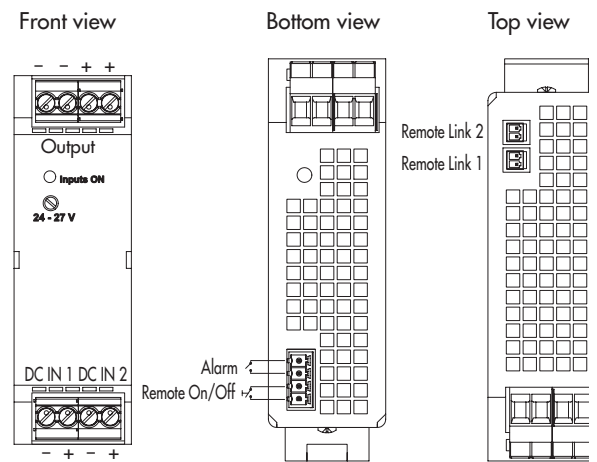

Specifications

Operating temperature	-25°C to +70°C max. derating above +40°C :1.5 %/K
Electromagnetic compatibility	in correspondence to connected units (no internal switching device)
Redundancy OK signal (Alarm)	trigger threshold at 18–22VDC, contact open if both inputs failed
Dimensions	see page 8
Remote link cable (0.5m)	2 cables included (order code TSPJC) www.tracopower.com/products/tsp-rc-cable.pdf
Remote On/Off	by ext. contact: contact open = On, contact closed = Off
Installation instructions	www.tracopower.com/products/tsp-rem_inst.pdf

TSP-BFM24 Buffer Module

The TSP-BFM24 buffer module will hold the output voltage of a 24 VDC power supply after brown outs or voltage dips of ten 50Hz cycles at full load. During this buffer period no deterioration of the 24 VDC output voltage will occur. For many applications this buffer module is an ideal and cost effective alternative to a battery based backup system. The buffer module consists of a large bank of capacitors. When the power supply is switched on, the buffer capacitors will be charged. This will take approximately 30 seconds and an opto-coupler signal indicates the "READY" condition. When a power fail occurs, the capacitor bank is discharged, maintaining the output of the buffer module at its nominal voltage. This condition is indicated by an "POWER FAIL" signal. The hold up time is typically 200 ms at 25 A and 4 seconds typically at 1,2A. After 4 seconds the buffer device will switch off the output voltage. The operation modes of the module are indicated by a LED on the front panel also. The big advantage of this buffer solution is, that it is fully maintenance free and its storage capability does not deteriorate over the live time of the product.



Models

Order Code (includes terminal plugs)	Operating Voltage Range	Buffer Time	Output Power max.
TSP-BFM24	24...28VDC	200ms typ. @ 25A max. 4.0 s max. @ 1.2 A	600 W

Function Diagram

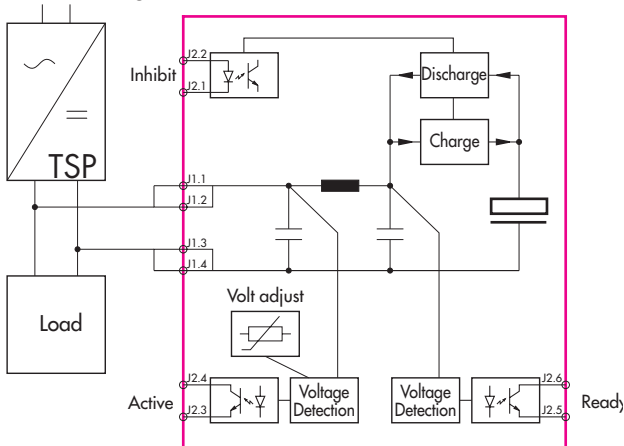

Connector Positions

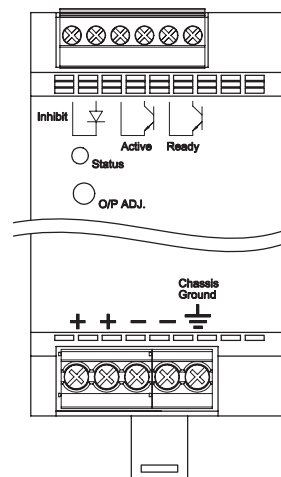

Specifications

Operating temperature	-25°C to +70°C max. derating above +40°C : 1.5 %/K
Electromagnetic compatibility	in correspondence to connected units (no internal switching device)
Buffer voltage	adjustable, >1 V below input voltage, min. 22 VDC
Charging	0.6 A max./30 s max.
Status signals	Buffer Active , Buffer Ready (optocoupler output) and dual colour LED for status indication
Inhibit	optocoupler input: 35 V max. < 5mA
Dimensions	see page 8
Installation instructions	www.tracopower.com/products/tsp-bfm_inst.pdf

TSP-BCM24 Battery Controller Module

This module provides a professional battery management system to charge and monitor an external lead-acid battery. Together with a power supply of the TSP series, a perfect DC-UPS system can be configured. The connected battery will be charged and held in charged mode by the power supply. In the event of a mains power failure the battery will supply the output power until the battery is discharged. As a consequence, the output voltage of the system is equivalent to the battery voltage. To avoid overcharging the battery, an external temperature sensor adjusts the battery voltage automatically to the required end of charge voltage. This can extend the battery life.

The battery is protected against deep discharge. Mains power and battery status are monitored regularly and failures indicated by corresponding LED's and alarm outputs. The module also provides an external On/Off input to switch-off both, power supply and battery.



TSP-TS battery temperature sensor (10 kOhm NTC with 2m cable) included

Models

Order code (includes terminal plugs)	Inputs	Input Power max	Output Voltage nom.	*Output Power max.
TSP-BCM24	24 VDC Power Supply	360 W	24 VDC	360 W
TSP-BCM24A	and 24 VDC Battery	600 W		600 W

*reduce max. output current by battery charging current

Function Diagram

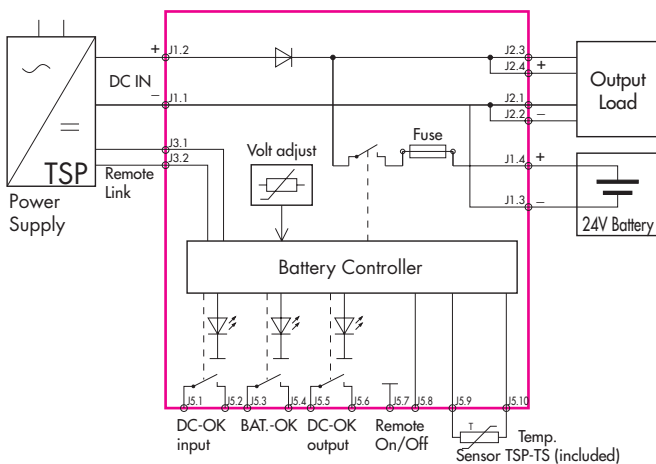

Connector Positions

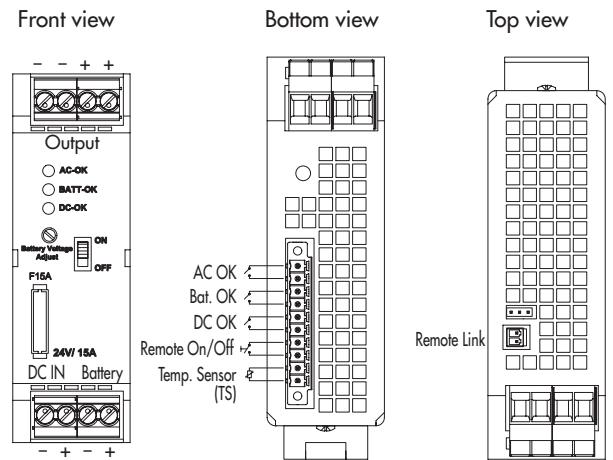

Specifications

Operating temperature	-25°C to +70°C max. derating above +40°C 1.5 %/K
Electromagnetic compatibility	in correspondence to connected units (no internal switching device)
Battery protection	over voltage, deep discharge, short circuit- and revers connection (built-in fuse)
Status signals	DC-OK input, DC-OK output, BAT OK all relay contact closed at status OK
Rating per relay contact	30 VDC/1.0 A max.
Dimensions	see page 8
Remote link cable (0.5m)	1 cable included (order code TSP-JC) www.tracopower.com/products/tsp-rc-cable.pdf
Remote On/Off	by ext. contact: contact open = On, contact closed = Off
Installation instructions	www.tracopower.com/products/tsp-bcm_inst.pdf

TSP-BAT Battery Pack

TSP battery packs are designed to build, in connection with the TSP-BCM battery controller module, a complete DC-UPS system. The entire range utilizes 12V maintenance free VRLA (valve regulated lead acid) batteries made by PANASONIC. These are not spillable lead gel type batteries. Two 12V batteries are connected in series and assembled into a stainless steel enclosure, with integrated connector and connection cable.



Models

Order Code (includes mating connectors)	Nominal Voltage	Charge Current max.	Nominal Capacity (at 25°C, 77°F)
TSP-BAT24-034	24 VDC	0.80 A	3.4 Ah
TSP-BAT24-072		1.75 A	7.2 Ah
TSP-BAT24-120		3.00 A	12.0 Ah

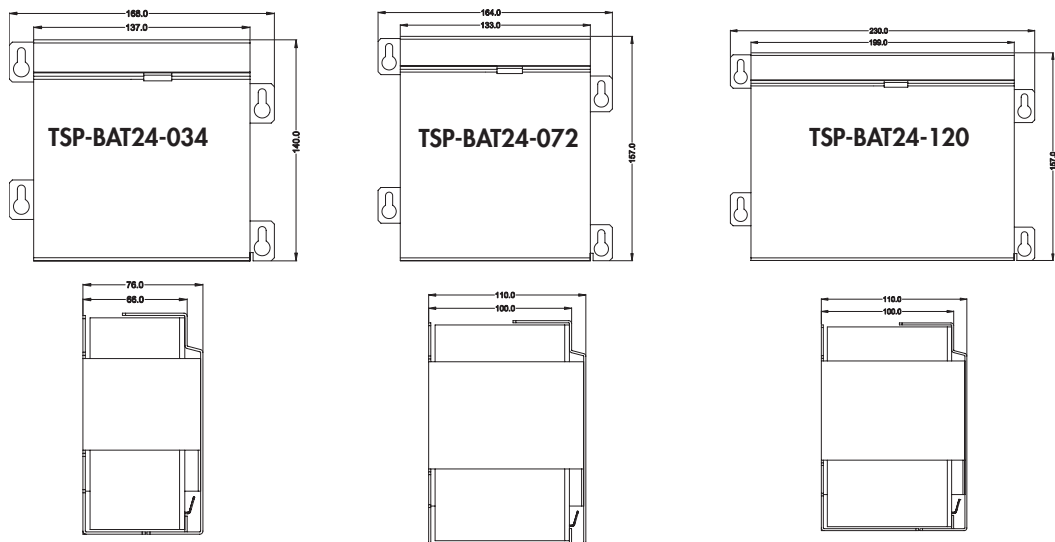

Detailed drawings in process

Specifications

Temperature ranges (max)	– during discharge – when charging / charged – storage	–15°C to +50°C max. 0°C to +40°C max. –15°C to +40°C max.
Battery lifetime		3-5 years see general battery information for details: www.tracopower.com/products/tsp-panas_gen.pdf
Remote link cable (0.5m)		1 cable included (order code TSPJC) www.tracopower.com/products/tsp-rc-cable.pdf
Weight	TSP-BAT24-034 TSP-BAT24-072 TSP-BAT24-120	3.2 kg (7.1 lb) 5.8 kg (12.9 lb) 9.0 kg (20.0 lb)
Battery datasheets	TSP-BAT24-034 TSP-BAT24-072 TSP-BAT24-120	www.tracopower.com/products/tsp-panas_034.pdf www.tracopower.com/products/tsp-panas_072.pdf www.tracopower.com/products/tsp-panas_120.pdf

Case Dimensions

Models:
TSP-REM360
TSP-BCM24

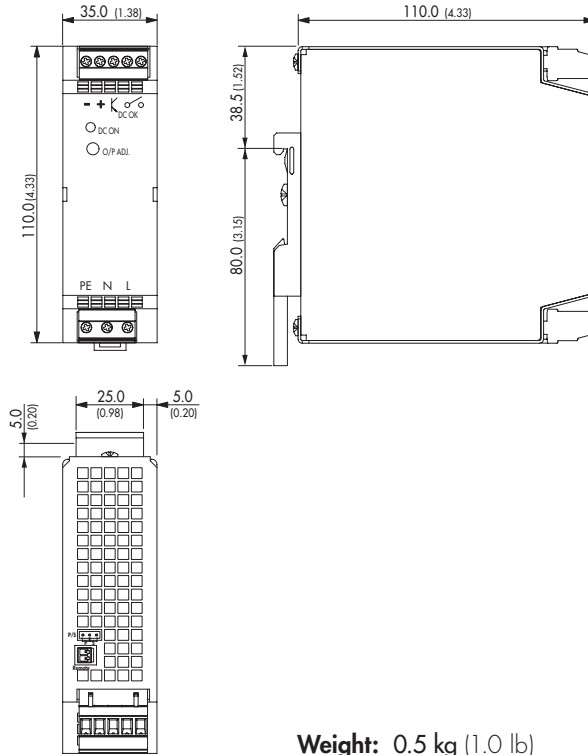

Models:
TSP 180-124WR
TSP-REM600
TSP-BCM24A
TSP-BFM24

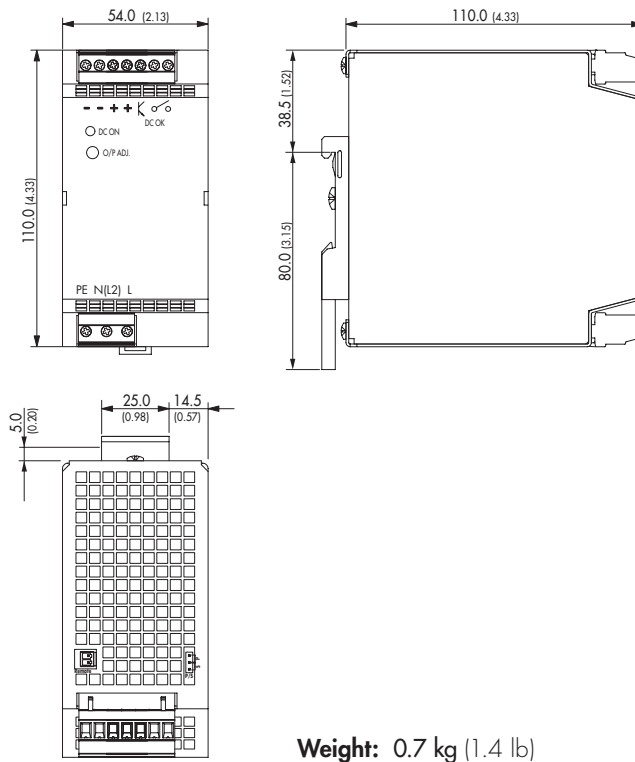

Dimensions in [mm], () = inch
Tolerances: ± 0.5 mm (± 0.02)

Case Dimensions

Model:
TSP 360-124WR

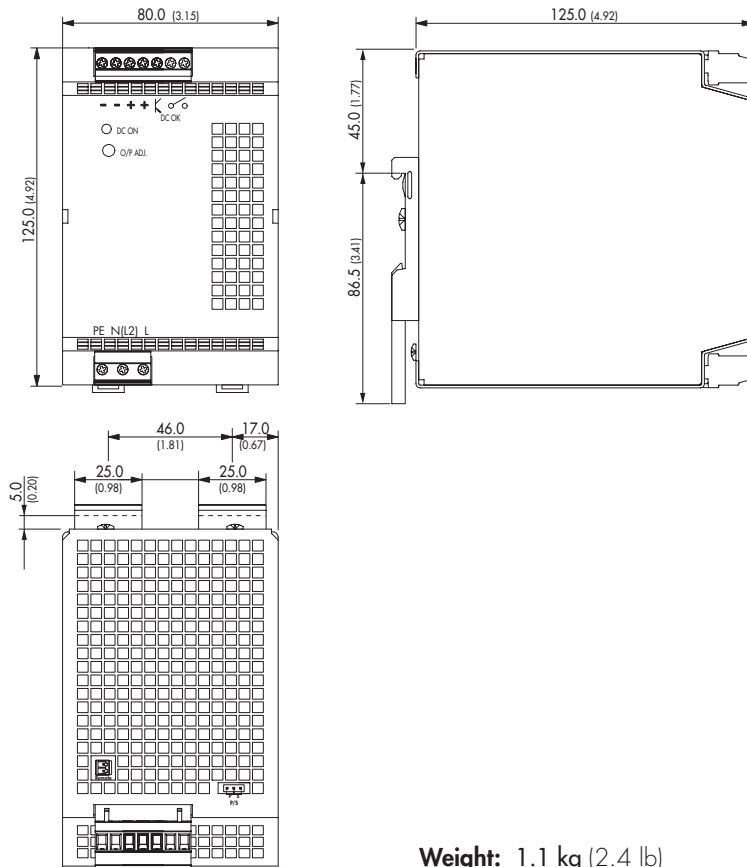

Weight: 1.1 kg (2.4 lb)

Dimensions in [mm], () = inch
Tolerances: ±0.5 mm (±0.02)

Case Dimensions

Model:
TSP 600-124WR

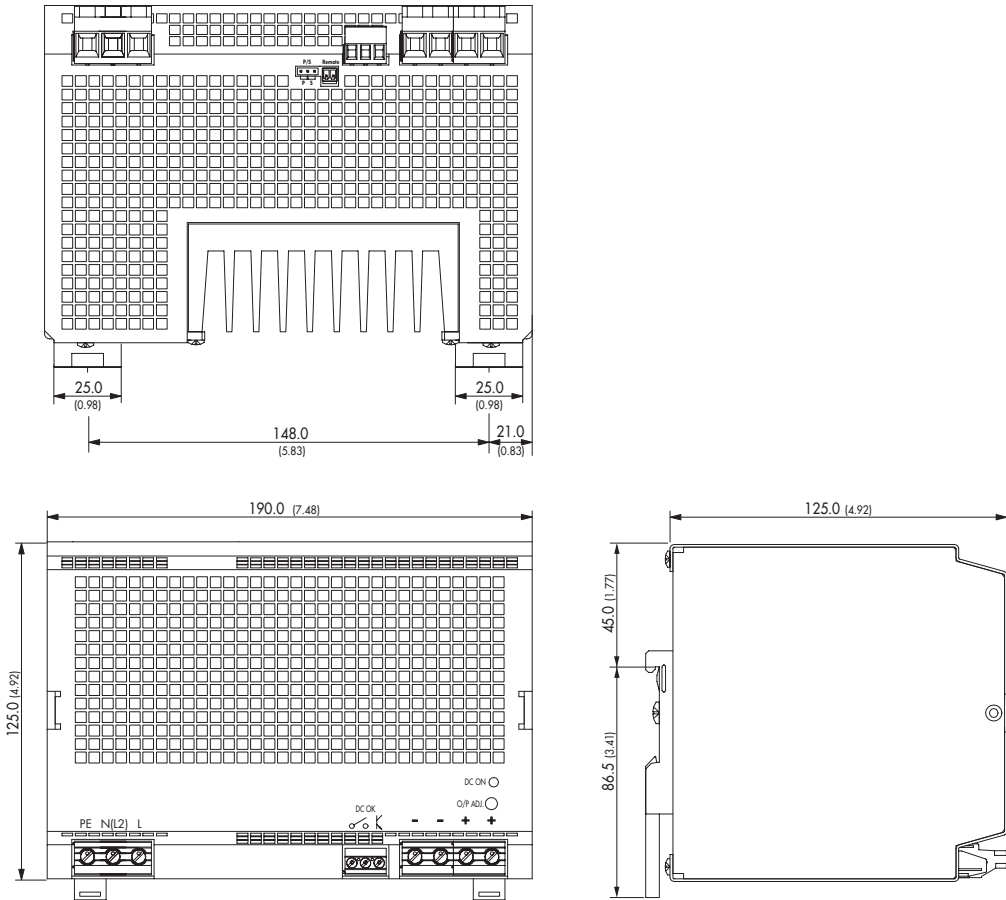

Weight: 3.0 kg (6.0 lb)

Dimensions in [mm], () = inch
Tolerances: ±0.5 mm (±0.02)

TSP-WMK Wall Mounting Bracket

Ordercode of kit	For models	Content of kit
TSP-WMK03	TSP 180-124WR, TSP-REM360, TSP-BCM24(A), TSP-BFM	1 bracket
TSP-WMK02	TSP 360-124WR, TSP 600-124WR	2 brackets

TSP-WMK03

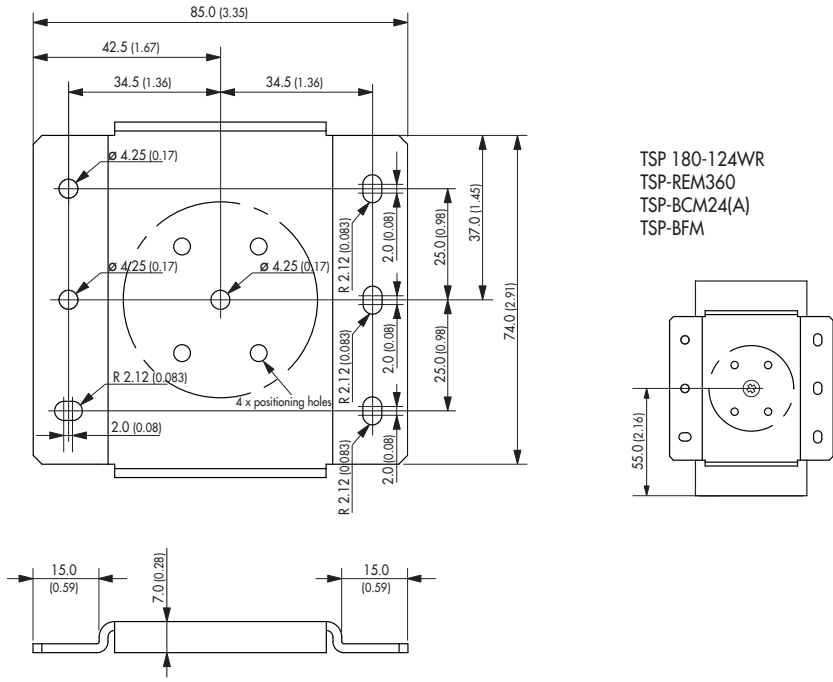

Material: 2 mm Mild Steel
Tolerance: ±0.1mm (± 0.004)

TSP-WMK02

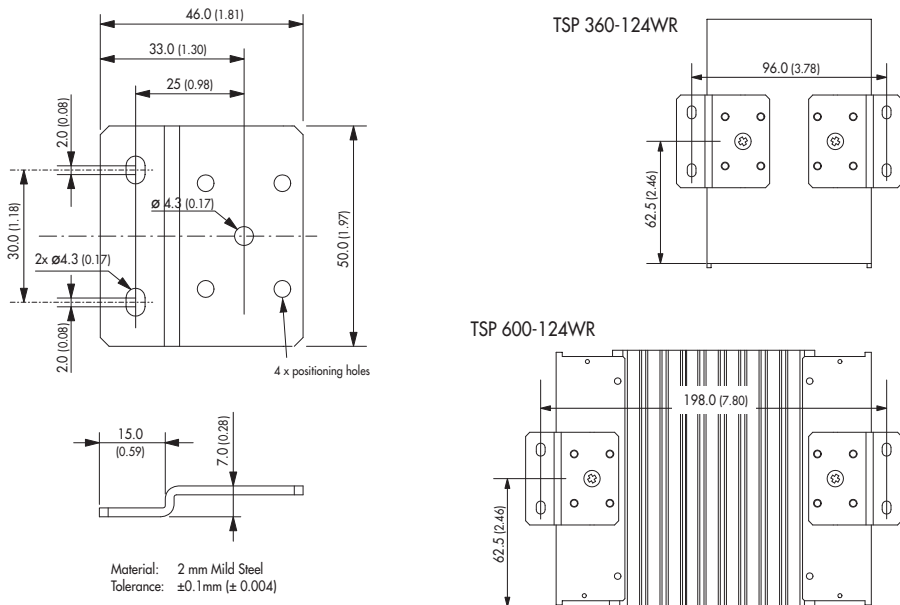

Material: 2 mm Mild Steel
Tolerance: ±0.1mm (± 0.004)

Specifications can be changed any time without notice.

Dimensions in [mm], () = Inch
Tolerances: ±0.5 mm (±0.02)